

Elektrische Vorkhefetrucks 6.0 - 8.0 ton

TRIGO⁸⁰



TOYOTA

MATERIAL HANDLING

Elektrische Vorkheftrucks 6.0 - 8.0 ton

Specificaties				9FBM60T	9FBM70T	9FBM80T	9FBH80T	
Kenmerken	1.1	Fabrikant		Toyota	Toyota	Toyota	Toyota	
	1.2	Type		9FBM60T	9FBM70T	9FBM80T	9FBH80T	
	1.3	Aandrijving		Elektro	Elektro	Elektro	Elektro	
	1.4	Besturing		Zittend	Zittend	Zittend	Zittend	
	1.5	Hefvermogen	Q	kg	6000	7000	8000	8000
	1.6	Bij lastzwaartepunt	c	mm	600	600	600	900
	1.8	Lastafstand	x	mm	700	710	715	750
	1.9	Wielbasis	y	mm	2300	2300	2300	2300
	Gewicht	2.1	Eigen gewicht		kg	12765	13476	14461
2.2		Asbelasting met last voor/achter		kg	16425 / 2340	18481 / 1995	20196 / 2265	21565 / 2553
2.3		Asbelasting zonder last voor/achter		kg	7034 / 5731	7494 / 5892	7622 / 6839	7826 / 8092
Wielen en banden	3.1	Banden - lucht (P), Volrubber(SE), Cushion(R)			SE	SE	SE	SE
	3.2	Bandenmaat voor			355/50-20	8.25-15	300-15	300-15
	3.3	Bandenmaat achter			8.25-15	8.25-15	300-15	300-15
	3.5	Wielen, aantal voor/achter (x = aangedreven)			2x/2	4x/2	4x/2	4x/2
	3.6	Spoorbreedte voor	b ₁₀	mm	1328	1510	1575	1575
	3.7	Spoorbreedte achter	b ₁₁	mm	1406	1406	1394	1394
	Afmetingen	4.1	Neiging mast/voorover/achterover	α/β	deg	5/8	5/8	5/8
4.2		Bouwhoogte, mast ingeschoven	h ₁	mm	2620	2720	2620	2670
4.3		Vrije heffing	h ₂	mm	100	100	100	100
4.4		Hefbeweging	h ₃	mm	3300	3300	3300	3300
		Hefhoogte	h ₂₃	mm	3360	3360	3360	3360
4.5		Hoogte, mast in hoogste stand	h ₄	mm	4237	4337	4255	4480
4.7		Hoogte beschermdak (cabine)	h ₆	mm	2835	2835	2835	2835
4.8		Zithoogte	h ₇	mm	1710	1710	1710	1710
4.12		Hoogte trekpen	h ₁₀	mm	785	785	785	785
4.19		Totale lengte	l ₁	mm	4680	4690	4695	5450
4.20		Lengte incl. vorkrug	l ₂	mm	3480	3490	3495	3650
4.21		Totale breedte	b ₁	mm	1660	2004	2141	2141
4.22		Vorkafmetingen	s/e/l	mm	60x200x1200	60x200x1200	60x200x1200	70x200x1800
4.23		Vorkenbord DIN 15 173, klasse/type A, B			IVA	IVA	IVA	IVA
4.24		Breedte vorkenbord	b ₃	mm	1600	1700	1700	1700
4.31		Bodemvrijheid belast, onderkant mast	m ₁	mm	220	220	220	220
4.32		Bodemvrijheid midden wielbasis	m ₂	mm	210	210	210	210
4.33		Gangpadbreedte bij pallets 1000 x 1200 dwars	A _{st}	mm	4705	4715	4720	4861
4.34	Gangpadbreedte bij pallets 800 x 1200 langs	A _{st}	mm	4905	4915	4920	5061	
4.35	Draaistraal	W _a	mm	3005	3005	3005	3111	
4.36	Binnenstraal	b ₁₃	mm	753	753	753	753	
Prestaties	5.1	Rijsnelheid met/zonder last		km/h	18/20	18/20	17/19	16/18
	5.2	Hefsnelheid met/zonder last		m/s	0,38/0,48	0,36/0,48	0,32/0,42	0,32/0,42
	5.3	Daalsnelheid met/zonder last		m/s	0,55/0,45	0,55/0,45	0,55/0,45	0,55/0,45
	5.5	Trekkracht met/zonder last		N	16573/17749	16237/17558	15848/17418	15562/17132
	5.6	Maximale trekkracht met/zonder last		N	44600 / 44600	44600 / 44600	44600 / 44600	44600 / 44600
	5.7	Klimvermogen met/zonder last		%	7/11	6,3/10,6	5,6/9,7	5,2/8,7
	5.8	Maximaal klimvermogen met/zonder last		%	19/29	18/27	16/25	16/23
	5.9	Versnellingsstijd met/zonder last		s	5,1/4,7	5,8/5,1	5,8/5,1	6,0/5,2
	5.10	Bedrijfsrem			Hydraulisch	Hydraulisch	Hydraulisch	Hydraulisch
	Motor	6.1	Rijmotorvermogen S2 60 min		kW	2x 21,2	2x 21,2	2x 21,2
6.2		Pompmotorvermogen bij S3 15%		kW	32	32	32	32
6.3		Batterij volgens DIN 43 531/35/36 A, B, C, nee			DIN 43536 A	DIN 43536 A	DIN 43536 A	DIN 43536 A
6.4		Batterijspanning/batterijcapaciteit K ₅		V/Ah	80/1120 (-1240)	80/1120 (-1240)	80/1120 (-1240)	80/1120 (-1240)
6.5		Batterijgewicht		kg	2785	2785	2785	2785
6.6		Energieverbruik VDI45 cyclus			12,3	13,4	14,8	15,8
Andere	8.1	Aandrijving			AC	AC	AC	AC
	8.2	Werkdruk voor aanbouwapparatuur		bar	250	250	250	250
	8.3	Olie voor aanbouwapparatuur		l/min	80	80	80	80
	8.4	Geluidsniveau op oorhoogte chauffeur, soort EN 12 053		dB(A)	65,8	65,8	65,8	65,8

De prestaties en afmetingen van de truck zijn gebaseerd op nominale waarden. Hierop zijn enige afwijkingen mogelijk. De producten van Toyota en de technische gegevens van de producten kunnen zonder voorafgaand bericht worden gewijzigd.

Mastspecificaties en restcapaciteit

Model			V							FV			FSV						
9FBM60T	Hefhoogte	h_{23}	3360	3760	4060	4560	5060	5560	6060	3360	3760	4060	4360	4760	5060	5560	6060	6560	7060
	Hefbeweging	h_3	3300	3700	4000	4500	5000	5500	6000	3300	3700	4000	4300	4700	5000	5500	6000	6500	7000
	Masthoogte, mast ingeschoven	h_1	2620	2820	3020	3270	3520	3770	4020	2620	2820	3020	2620	2720	2820	3020	3220	3420	3620
	Masthoogte, in hoogste stand	h_4	4252	4652	4970	5470	5970	6470	6970	4280	4680	4980	5280	5680	5980	6480	6980	7480	7980
	Vrije heffing	h_2	100	100	100	100	100	100	100	1705	1905	2055	1655	1755	1855	2055	2255	2455	2655
9FBM70T	Hefhoogte	h_{23}	3360	3760	4060	4560	5060	5560	6060	3360	3760	4060	4360	4760	5060	5560	6060	6560	7060
	Hefbeweging	h_3	3300	3700	4000	4500	5000	5500	6000	3300	3700	4000	4300	4700	5000	5500	6000	6500	7000
	Masthoogte, mast ingeschoven	h_1	2720	2920	3120	3370	3620	3870	4120	2720	2920	3120	2620	2720	2820	3020	3220	3420	3620
	Masthoogte, in hoogste stand	h_4	4352	4752	5070	5570	6070	6570	7070	4280	4680	4980	5280	5680	5980	6480	6980	7480	7980
	Vrije heffing	h_2	100	100	100	100	100	100	100	1740	1940	2140	1655	1755	1855	2055	2255	2455	2655
9FBM80T	Hefhoogte	h_{23}	3360	3760	4060	4560	5060	5560	6060	3360	3760	4060	4360	4760	5060	5560	6060	6560	7060
	Hefbeweging	h_3	3300	3700	4000	4500	5000	5500	6000	3300	3700	4000	4300	4700	5000	5500	6000	6500	7000
	Masthoogte, mast ingeschoven	h_1	2620	2920	3120	3370	3620	3870	4120	2670	2920	3120	2690	2820	2920	3090	3260	3430	3620
	Masthoogte, in hoogste stand	h_4	4255	4720	5070	5570	6070	6570	7070	4334	4734	5034	5353	5753	6053	6553	7053	7553	8053
	Vrije heffing	h_2	100	100	100	100	100	100	100	1705	1955	2155	1710	1840	1940	2110	2280	2450	2640
9FBH80T	Hefhoogte	h_{23}	3360	3760	4060	4560	5060	5560	6060	3360	3760	4060	4360	4760	5060	5560	6060	6560	7060
	Hefbeweging	h_3	3300	3700	4000	4500	5000	5500	6000	3300	3700	4000	4300	4700	5000	5500	6000	6500	7000
	Masthoogte, mast ingeschoven	h_1	2820	3120	3320	3570	3820	4070	4320	2770	3020	3220	2820	2950	3050	3220	3390	3550	3720
	Masthoogte, in hoogste stand	h_4	4480	4920	5270	5770	6270	6770	7270	4334	4734	5034	5575	5975	6275	6775	7275	7775	8275
	Vrije heffing	h_2	100	100	100	100	100	100	100	1745	1995	2195	1545	1675	1775	1945	2115	2275	2445

Enkele wielen			V							FV			FSV						
9FBM60T	Neighoek, voorw.	deg	5	5	5	5	5	5	5	5	5	5	5	5	5	5	5	5	5
	Neighoek, achterw.	deg	8	8	8	8	8	8	8	8	8	8	8	8	8	8	8	8	8
	Hefvermogen op 600 mm LC	kg	6000	6000	6000	6000	6000	6000	6000	6000	6000	6000	6000	6000	6000	6000	6000	6000	6000

Dubbele wielen			V							FV			FSV						
9FBM70T	Neighoek, voorw.	deg	5	5	5	5	5	5	5	5	5	5	5	5	5	5	5	5	5
	Neighoek, achterw.	deg	8	8	8	8	8	8	8	8	8	8	8	8	8	8	8	8	8
	Hefvermogen op 600 mm LC	kg	7000	7000	7000	7000	7000	7000	7000	7000	7000	7000	7000	7000	7000	7000	7000	7000	7000
9FBM80T	Neighoek, voorw.	deg	5	5	5	5	5	5	5	5	5	5	5	5	5	5	5	5	5
	Neighoek, achterw.	deg	8	8	8	8	8	8	8	8	8	8	8	8	8	8	8	8	8
	Hefvermogen op 600 mm LC	kg	8000	8000	8000	8000	8000	8000	7700	8000	8000	8000	8000	8000	8000	8000	7700	7500	7500
9FBH80T	Neighoek, voorw.	deg	5	5	5	5	5	5	5	5	5	5	5	5	5	5	5	5	5
	Neighoek, achterw.	deg	8	8	8	8	8	8	8	8	8	8	8	8	8	8	8	8	8
	Hefvermogen op 900 mm LC	kg	8000	8000	8000	8000	7700	7700	7500	8000	8000	8000	8000	8000	8000	8000	7700	7300	7300

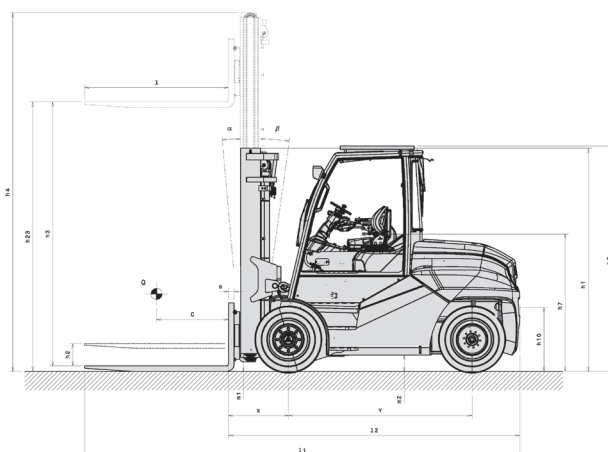
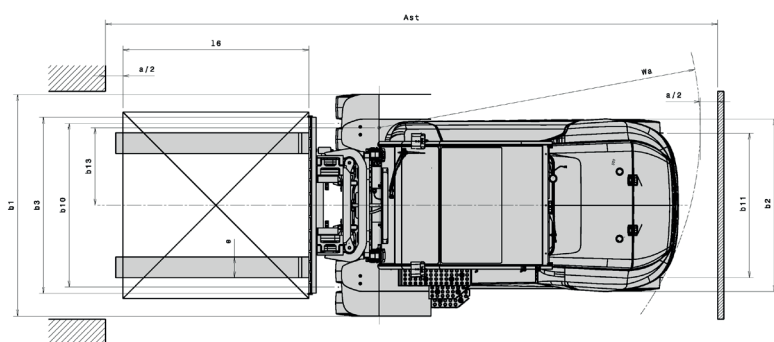

Standaard uitrusting

- Toyota SAS (Systeem van Actieve Stabiliteit)
- Toyota AC² Systeem
- Toyota OPS (Operator Presence Sensing), Toyota ORS stoel (Operator Restraint System)
- Aan stoel gemonteerde armsteun met minilevers
- Doorkijkmast (V3300 mm), beschermdak (hoogte: 1220 mm)
- Lange vorken, lengte: 1200 mm (9FBM60-80T), 1800 mm (9FBH80T)
- Automatische parkeerrem, Oliebadremmen, Brede rempedaal
- 4^e stuurventiel
- Elektronische power steering (EPS)
- Digitaal multifunctioneel display met wielstandindicatie
- Telescopische, kantelbare stuurkolom
- Pneumatische luchtbanden, enkel (9FBM60T); dubbel (9FBM70-80T, 9FBH80T)
- Zwevende bestuurderscabine
- Schokvrij dalen
- Alle onderdelen volledig afgeschermd
- Dubbele handgrepen



Beersebaan71-2310 Rijkevorsel

Tel.: 03/340.04.90

Fax: 03/340.04.91

www.hermans-heftrucks.be

info@hermans-heftrucks.be

TOYOTA

MATERIAL HANDLING